

This information is confidential and proprietary to ZAWARD.
 And shall not be reproduced or further disclosed to anyone other than ZAWARD employees without prior written consent from ZAWARD.
 Any uncontrolled printed copy of this document is for reference purpose only unless expressly authorized by ZAWARD.
 Authorization must include number and revision.

REVISIONS			
MARK	REV.	DESCRIPTION	DATE
	A	Formal Release	12/15/2010
	B	Both sides to increase M3	02/28/2011

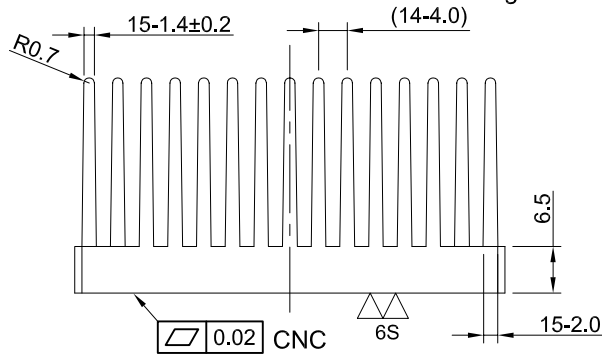
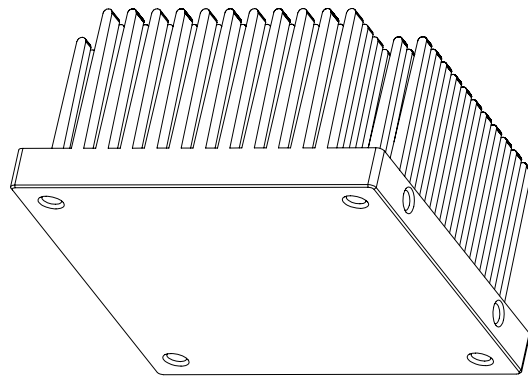
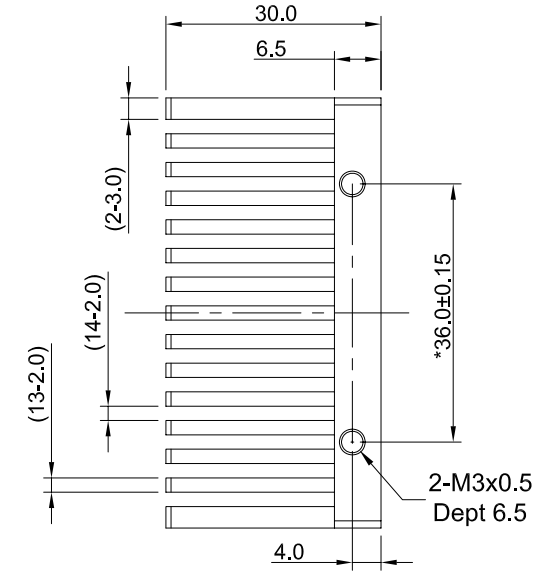
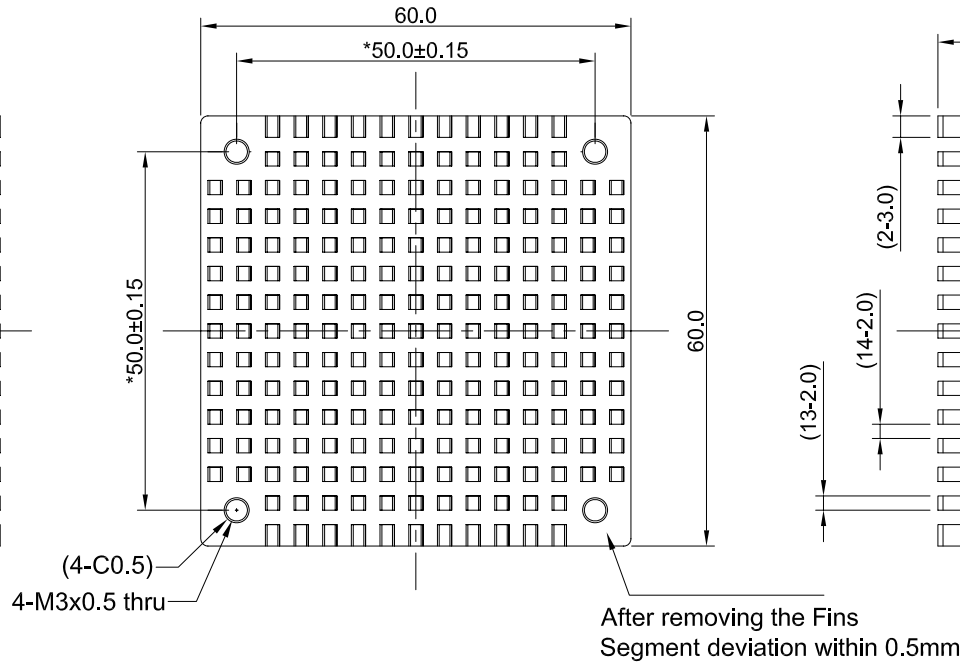
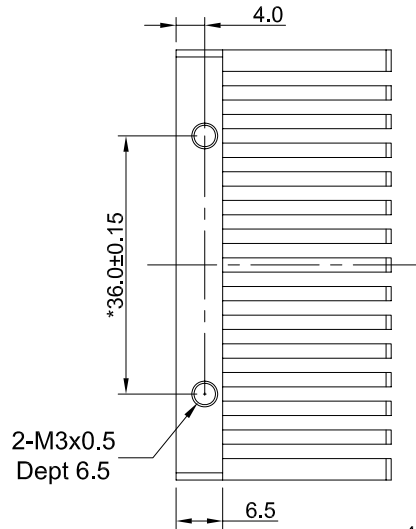

Note:

1. Material: Al6063-T5.
2. Surface treatment: Clear Anodized, with nature anodized thickness more than 5µm.
3. Surface is not allowed scratches, burrs, oils.
4. R angle is less than 0.3 if without noted.
5. All parts must free of burrs, Required to blunt the sharp edges.
6. All parts are ROHS compliance.

GENERAL TOLERANCE, ALL DIMENSIONS ARE IN mm		
DIMENSIONS	METAL TOLERANCE	FIN ASSEMBLY TOLERANCE
Over 120	±0.30	±0.50
60~120	±0.25	±0.40
31~60	±0.20	±0.30
0~30	±0.15	±0.20
ANGLES	0.3°	0.3°

ZAWARD CORPORATION

PART NO.		30EC60L60C		PART TITLE		Heatsink	
MATERIAL		AL6063-T5		FINISH		Clear Anodized	
SCALE	1:1		DATE		02/28/2011		REV.
SIZE	SHEET		ROHS		WEIGHT		REFERABLE
A4	1/1		YES		110g		B

APPROVED	Carmen	CHECKED	Gary	DRAWN	Alin	VIEW		mm
----------	--------	---------	------	-------	------	------	--	----

A B C D E F G