

This information is confidential and proprietary to ZAWARD.
 And shall not be reproduced or further disclosed to anyone other than
 ZAWARD employees without prior written consent from ZAWARD.
 Any uncontrolled printed copy of this document is for reference purpose
 only unless expressly authorized by ZAWARD.
 Authorization must include number and revision.

REVISIONS			
MARK	REV.	DESCRIPTION	DATE
	A	Formal Release	08/11/2013

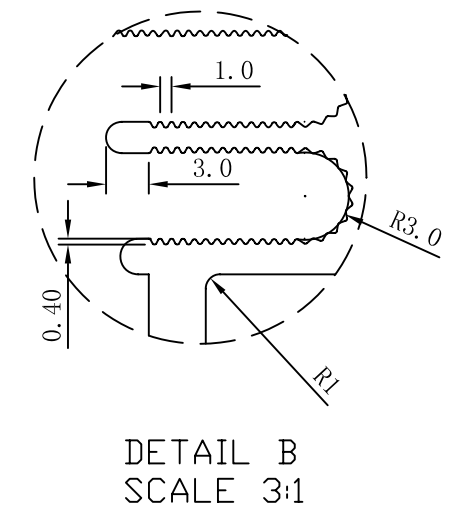
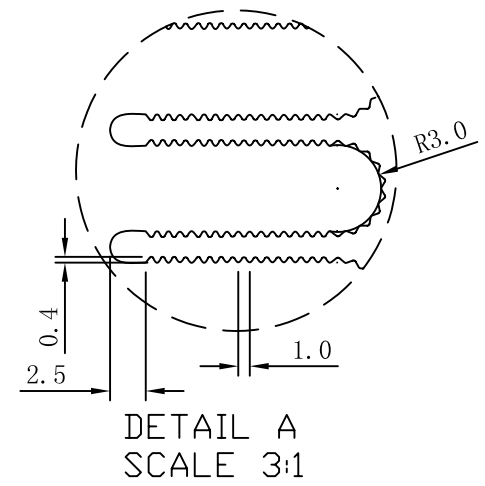
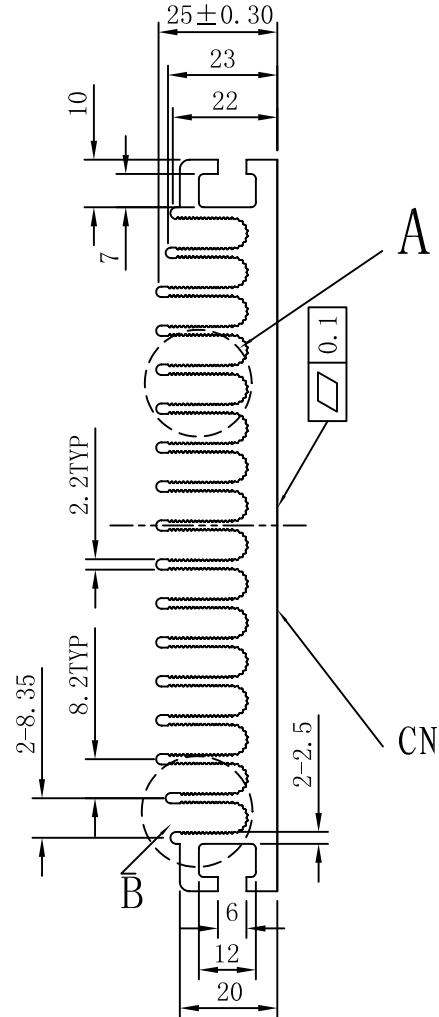
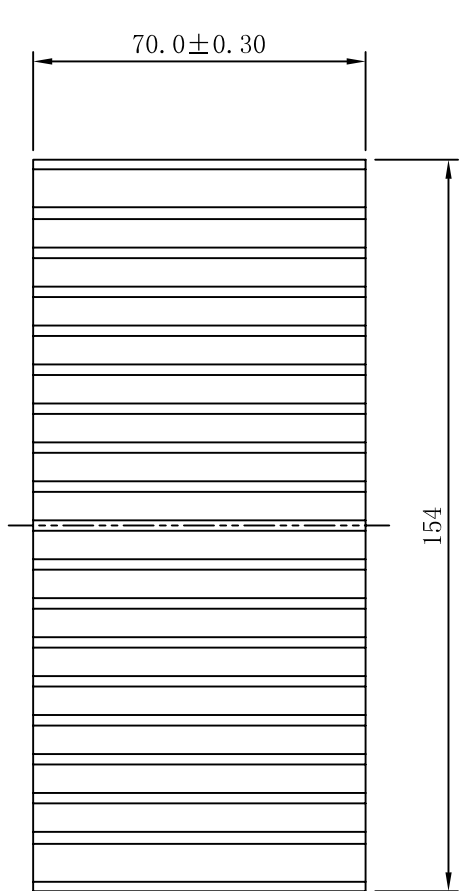

Note:

1. Material: Al6063-T5
2. Surface treatment: Clear Anodized with nature anodized thickness more than $5\mu\text{m}$
3. Surface is not allowed scratches, burrs, oils.
4. R angle is less than 0.3 if without noted, All parts must free of burrs.
5. All parts are ROHS compliance

GENERAL TOLERANCE, ALL DIMENSIONS ARE IN mm		
DIMENSIONS	METAL TOLERANCE	SEMI ASSEMBLY TOLERANCE
Over 120	± 0.50	± 0.80
60~120	± 0.40	± 0.50
31~60	± 0.30	± 0.40
0~30	± 0.20	± 0.30
ANGLES	0.3°	0.3°

ZAWARD CORPORATION

PART NO.		25FX154L70C		PART TITLE		Heat sink	
MATERIAL		AL6063-T5		FINISH	Clear Anodized	SCALE	1:1
SIZE	SHEET	ROHS	WEIGHT	REFERABLE	DATE	REV.	
A4	1/1	YES			08/13/2011	A	

APPROVED	Carmen	CHECKED	Gary	DRAWN	Alin	VIEW		mm
----------	--------	---------	------	-------	------	------	--	----