

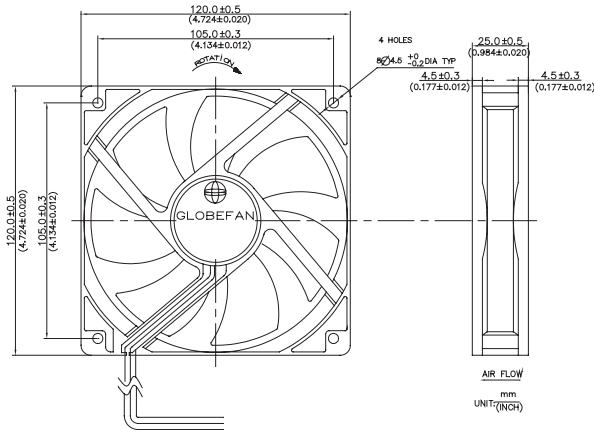

Casting and Impeller Material: Plastic (UL 94V-O)
Bearing system: Ball Bearing (B) Sleeve Bearing (S)
Lead Wires: UL 1007 AWG 24 or equivalent. Red:+, Black:-, Sensor: Yellow or White.
Model No: X1202512Y X=Bearing system, can be B or S type. Y=Fan speed, can be L, M or H.
Options: Auto-restart, FG
Net Weight: 134.0g

Model No. X1202512Y 120×120×25 mm (4.72"×4.72"×0.98")



外形圖 外形図 Outline

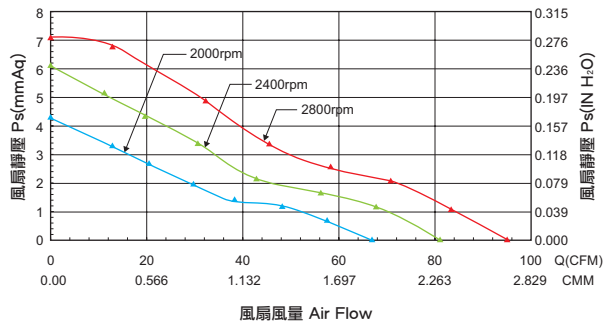

風量, 靜壓特性曲線
風量, 静圧特性カーブ
Characteristic Curves

Specifications

ITEM		MODEL NO.	X1202512L	X1202512M	X1202512H
RATED VOLTAGE 定格電圧	額定電壓 (V)		12	12	12
OPERATING VOLTAGE 動作電圧	操縱電壓 (V)		6-13.8	6-13.8	6-13.8
RATED CURRENT 定格電流	額定電流 (A)		0.18	0.30	0.52
STARTING VOLTAGE 起動電圧	啟動電壓 (V)		6	6	6
RATED INPUT POWER 定格入力	額定功率 (W)		2.16	3.60	6.24
MAX AIR FLOW 最大風量	最大風量 (CFM)		67.28	80.98	94.92
	最大風量 (CMM)		1.903	2.291	2.685
MAX STATIC PRESSURE 最大静圧	最大靜壓 (mmAq)		4.31	6.14	7.13
	最大靜壓 (IN H ₂ O)		0.170	0.242	0.281
NOISE VALUE 騒音値	噪音值 (dBA)		34.0	39.0	43.6
RATED SPEED 回轉數	額定轉速 (rpm ± 10%)		2000	2400	2800